

Specification and Order Sheet

Dimensions

- please circle required size or enter measurement

A Diameter (mm)	600 750 1000
B Height* (mm)	1000 2000 3000 4000 5000
C Inlet Diameter (mm)	110 150 200
D Inlet distance from base	mm
E Outlet Diameter (mm)	TBA - Morclean to specify
F Outlet distance from base	mm
G Power Inlet Diameter (mm)	110

*The height can be an entirely customized size, as long as it's between 1000 mm and 5000 mm, made exactly to your own requirements. Please ask our sales team about this option.

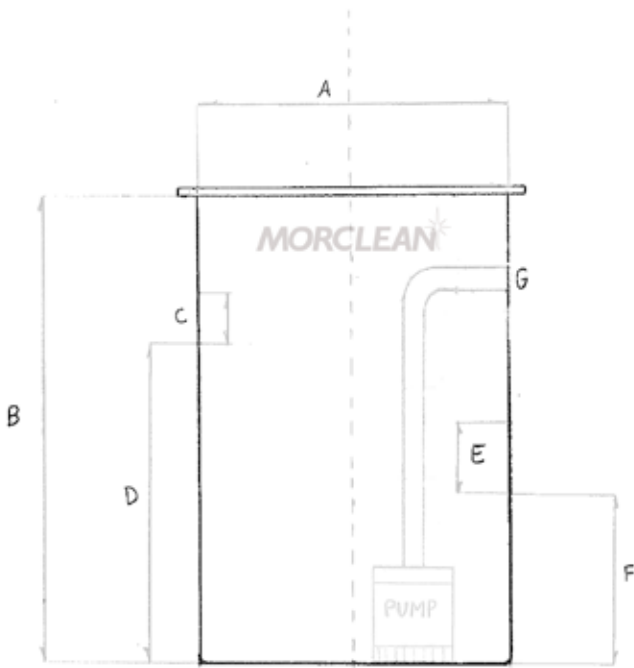

EXAMPLE

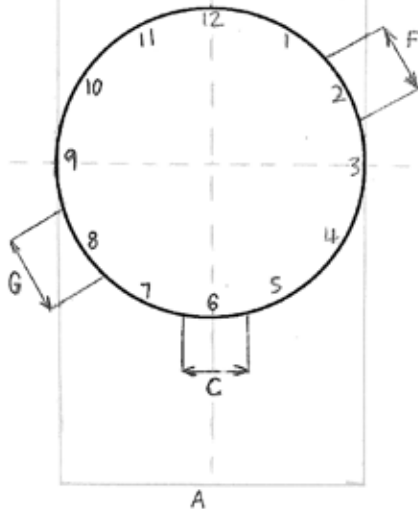

NOW YOUR TURN

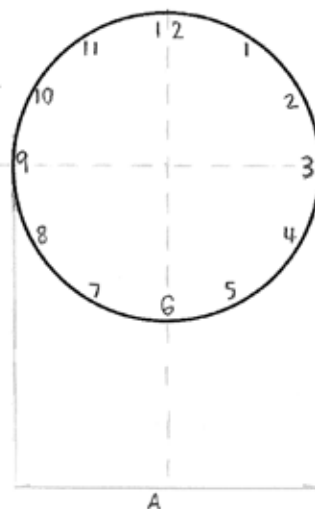

Plan of Chamber

The inlets and outlets on the pumping chamber can be positioned exactly where required. These are inlet (C), outlet (F) and power inlet (G). On the diagram to the left, please indicate where you would like them placed. Also, in the table below, please enter the number indicating the placement. Please see example diagram far left if you are unsure how to do this.

Example Specification

C Inlet	6
F Outlet	2
G Power Inlet	8

Your Specification

C Inlet	
F Outlet	
G Power Inlet	

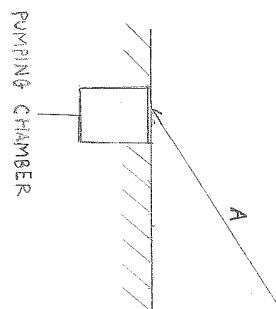

Placements - Please observe the diagram to the left and enter the distances required in meters.

A - Rise in Height (Head)	m
B - Any prior or subsequent reduction in levels	m
C - Total Linear Distance	m

Ground Level

Pumping Chamber

For Office Use:

Client: _____

Reference No: _____



Morclean Ltd, Stephenson Road, Speedwell Industrial Estate, Staveley, Chesterfield S43 3JN, UK.
Tel: +44 (0)1246 471147 Fax: +44 (0)1246 471277 sales@morclean.co.uk www.morclean.co.uk
Registered in England No.465133

Morclean reserve the rights to update and amend the specification of any of our equipment & accessories in the interest of the customer. All prices subject to VAT @ SR. (E & O.E)